

ADA Transfer Shower
SUBMITTAL DATA
HANDLED BY THE VALVE

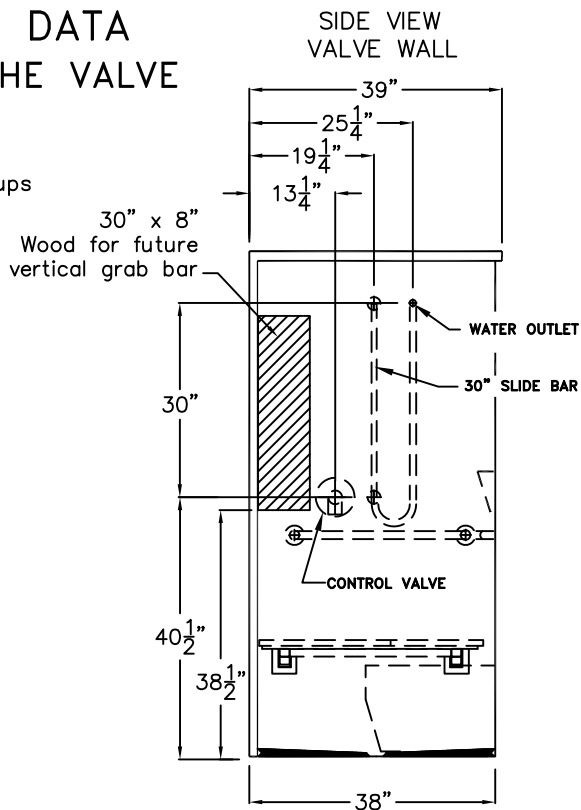
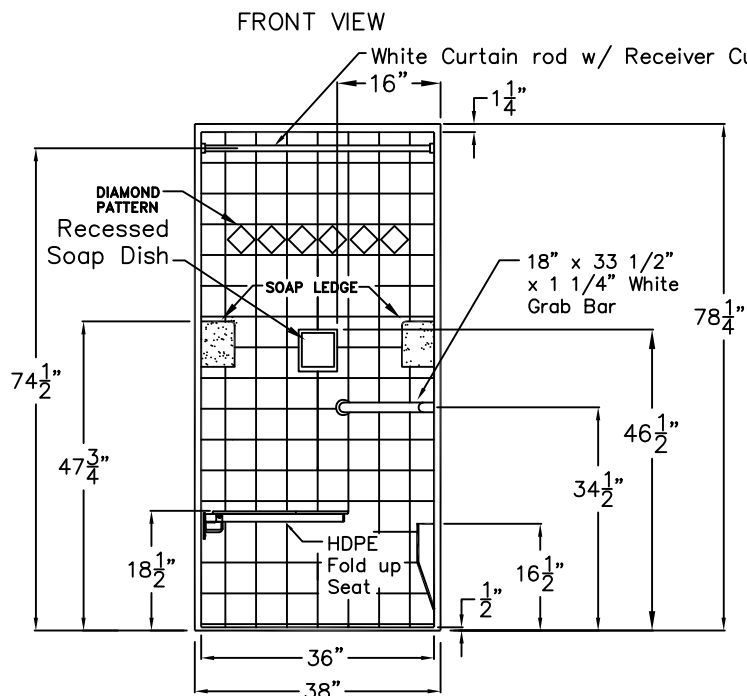

Transfer Shower Stall

The shower enclosure shall be Comfort Designs Model XST3838BFADA.5 right or left. Finished surface shall be of a sanitary-grade polyester Gelcoat exhibiting a minimal thickness of 15 dry mills, and a finished cured Barcol hardness of 80-90 as tested with ASTM D-2583. Unit construction shall be of molded reinforced fiberglass with a 15% minimum fiberglass content. The unit shall have outside dimensions of 38" x 39" x 78 1/4". The base shall be attached to the sump of the unit in such a manner to form an integral part with an inner and outer coating of reinforced polyester resin. The unit shall meet ANSI 117.1, ANSI 124.2, ADA, HUD, BOCA, NAHB, UPC, and shall meet the requirements of Southern Building Code. Meets CSA standards.

The enclosure shall be equipped with the following installed accessories:

- 1) one 18" x 33 1/2" x 1 1/4" diameter, white L- grab bar with 1 1/2" statute clearance, mounted with stainless steel bolts and secured from the rear with a 3" x 3" x 11 gauge metal mounting plate,
- 2) Wood for future vertical bar on valve side wall,
- 3) White curtain rod with receiver cups,
- 4) 1/2" threshold,
- 5) HDPE Fold up seat,
- 6) molded soap dish,
- 7) Tile finish,
- 8) diamond pattern,
- 9) foot ledge,
- 10) Recessed Soap dish,
- 11) valve package, includes: control valve, hand held shower, 60" flex hose, 30' slide bar, swivel connector and wall fitting.

Available Options: 1) Hand held shower set (includes: hand set, 60" flex hose, swivel connector, vacuum breaker, brass nipple, locknut, wall brackets and shower wall outlet), 2) Factory installed fold up seat, 3) 24" or 30" slide bar, 4) Pressure balance valve, 5) Green shower curtain, anti-bacterial, and hooks, 6) White shower curtain and hooks.

NOTE: THIS UNIT WILL NOT ACCEPT A DOOR!

TOP VIEW

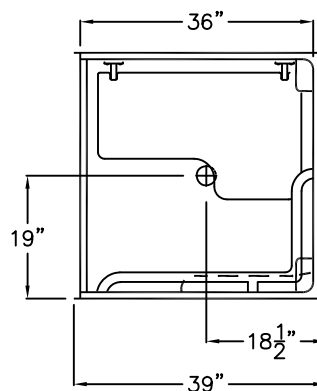

DUE TO THE NATURE OF THE MATERIALS DIMENSIONS MAY VARY ± 1/2"

Job Name:	
Model No.:	Drawing#: XST 3838 BF .50 SB WFVB FHDP WCR VP RSD
Approved by:	Date Approved: Date: 5-21-07 Revised: 5-26-10
Rep.:	Wholesaler: Quote No.:

BOARD PLACEMENT SUBMITTAL DATA

FRONT VIEW

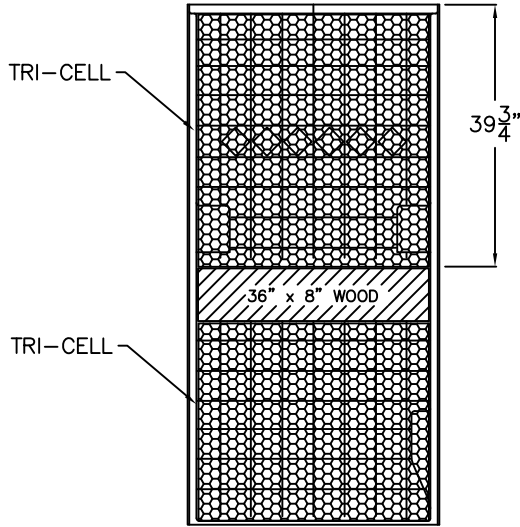

VALVE SIDE VIEW

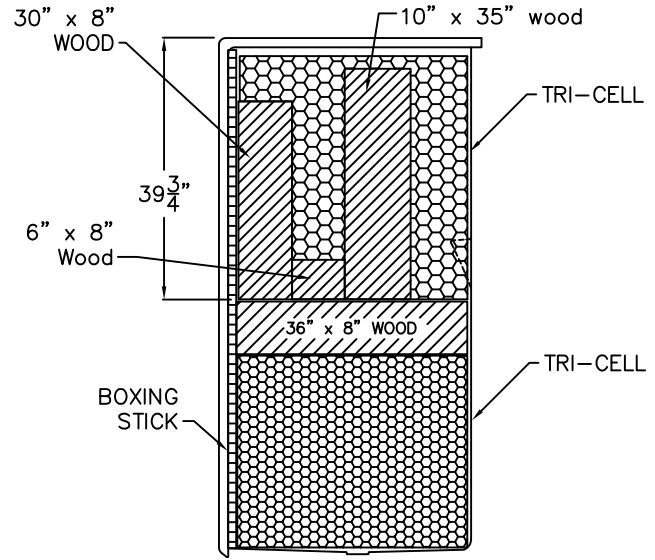

SEAT SIDE VIEW

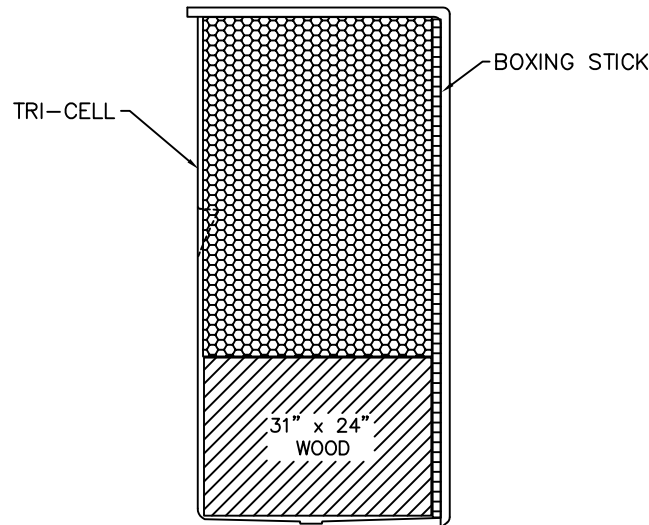

DUE TO THE NATURE OF THE MATERIALS
DIMENSIONS MAY VARY ± 1/2"

Job Name:			
Model No.:		Drawing#: XST 3838 BF .50 SB VB FS VP-BP	
Approved by:	Date Approved:	Date: 4-21-07	Revised: 5-26-10
Rep.:	Wholesaler:	Quote No.:	

Comfort Series

SUBMITTAL DATA

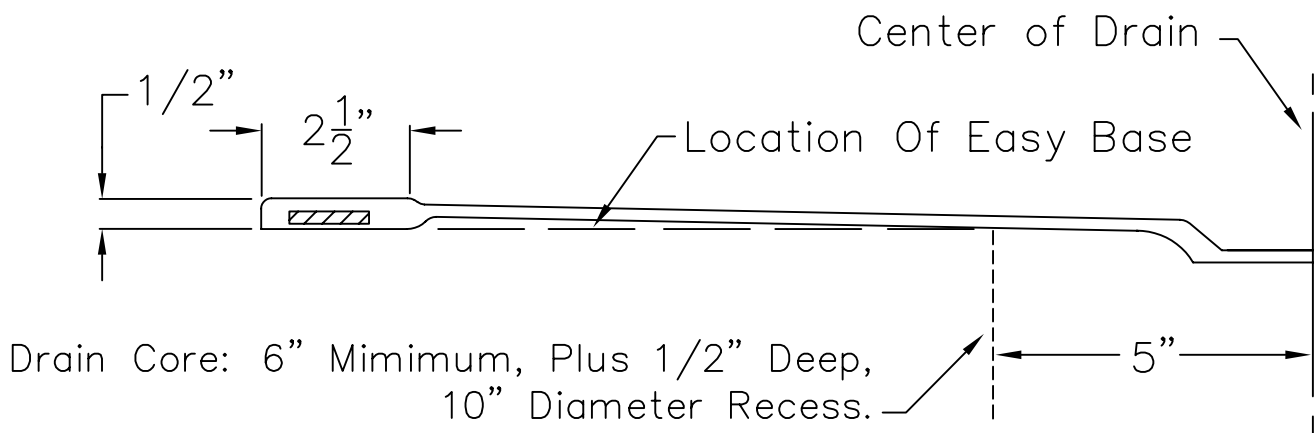

THRESHOLD DETAIL

DUE TO THE NATURE OF THE MATERIALS INVOLVED
UNIT DIMENSIONS MAY VARY ± 1/2 INCH

Job Name:	ACCESSIBILLITY PROFESSIONALS
Model No.:	Drawing#: 3838 BF .50 Detail
Approved by:	Date Approved: Date: 3-31-09 Revised: 12-9-10
Rep.:	Wholesaler: Quote No.

PRAXIS INDUSTRIES, INC.
ROUTE 1, BOX 46D - SAVANNAH, TN 38372
1 (800) 443-7269 - FAX (901) 925-4290

Recyclable Paper